



Student's name

For Examiner's Use

TOTAL

/44

Y9 / Y10 Mathematics Potential Assessment

Time allowed: 75 minutes

Instructions:

- Use black ink or black ball-point pen.
- Answer all questions
- Without sufficient working, correct answers may be awarded no marks
- Answer only in the spaces provided – there may be more space than you need
- Calculators may **NOT** be used

Information

- The marks for questions are shown in each section.
- There are 40 questions
- The maximum mark for this paper is 44

Advice

- Read each question carefully before you start to answer it
- Check your answers if you have time at the end

Section 1: Numeracy

All questions are worth 1 mark

Q1

Write these numbers in order of size. Start with the smallest decimal.

20.1023, 20.712, 20.569, 20.99, 20.4

Q2

Write $\frac{17}{20}$ as a percentage

Q3

Write 65% as a fraction in its simplest form

Q4

Write 0.034 as a percentage.

Q5

Write 6.4891 correct to 1 decimal place

Q6

Work out $\sqrt{1.21}$

Q7

Work out $1\frac{3}{4}$ of 14

Q8

Write the number 4.052×10^2 as an ordinary number

Q9

Work out $\left(2\frac{1}{3} - 1\frac{5}{9}\right) \times 1.5$

Q10

Solve $\frac{(-4)^2 \div 2^3}{\sqrt{36} \div 12}$

Q11

A dress costing \$80 is increased in price by 30%. What is the new price?

Q12

In a sale on furniture there is a 10% reduction in prices.
After the reduction, the price of a sofa is now £1800.
Work out the price of the sofa before the reduction.

Q13

If it takes 5 men 16 days to build a wall, how many days does it take 8 men to build the same size wall?

Q14

The ratio of cars to lorries on a road is 5 : 2. If there are 21 more cars than lorries, how many lorries are there on the road?

Section 2: Algebra

All questions are worth one mark

Q15

Fully simplify $(2p^2q^3)^2$

Q16

Fully simplify $3a^{2n} \times 7a^{n-1}$

Q17

Expand and simplify $3(6 - x) - 2(x + 4)$

Q18

Expand and simplify $(6 - 2x)(x + 3)$

Q19

Solve $4(2x - 1) - 4 = 1 - \frac{x+2}{3}$

Questions 20 to 22 are based on the following pattern:

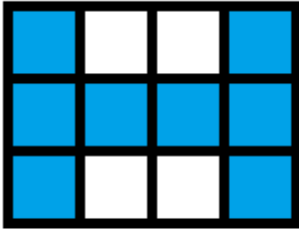

Pattern 1

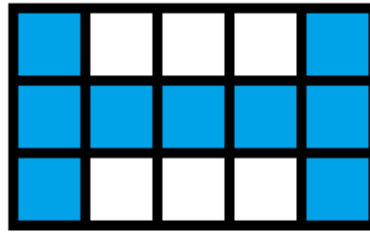

Pattern 2

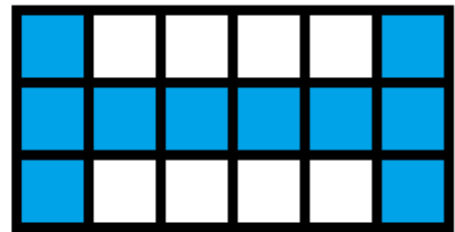

Pattern 3

Q20

How many shaded tiles are in Pattern 5?

Q21

If there are 29 shaded tiles in a pattern, what is the pattern number?

Q22

Find an expression, in terms of n , for the number of unshaded tiles in pattern n .

Q23

Rearrange the following equation for P

$$Q = \frac{P + 4}{5 - P}$$

Q24

Solve the simultaneous equations

$$3x + 5y = 7$$

$$4x - 2y = 10$$

Q25

Rearrange the following equation for x

$$P = B - \sqrt{x}$$

Section 3: Geometry

All questions are worth one mark

Q26

Two triangles share a common side as seen below.
Work out the size of the angle marked x°

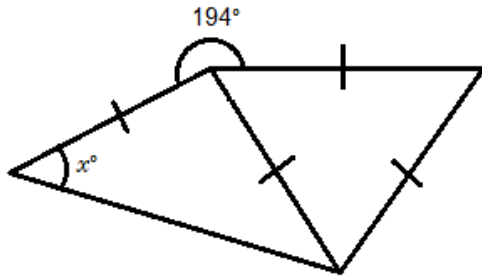

Diagram **NOT**
accurately drawn

Q27

A kite and a square share a common side as seen below.
Find the size of the angle marked x°

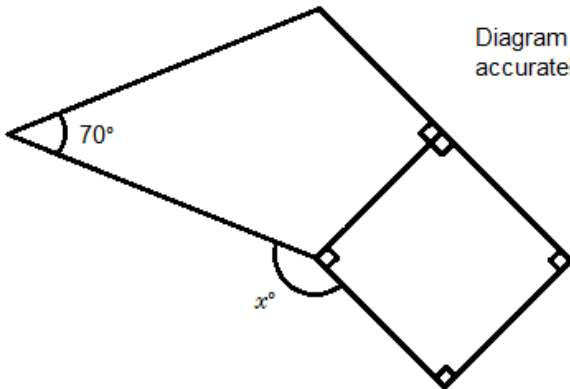
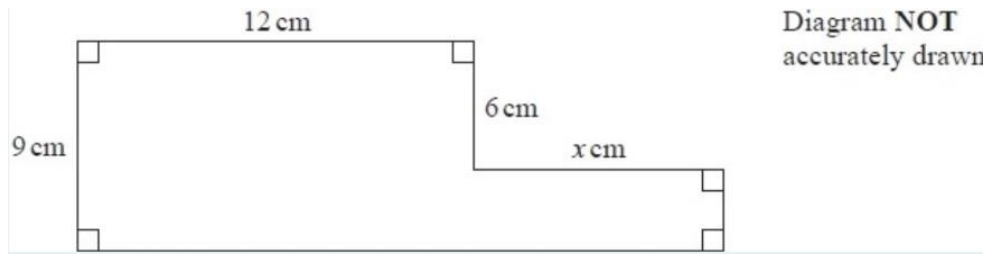

Diagram **NOT**
accurately drawn

Q28

The diagram shows a shape.

The shape has a perimeter of 58cm. Work out the value of x



Q29

The diagram shows an Isosceles triangle.

What is the area of the triangle?

Give you answer in a surd form. i.e. $a\sqrt{b}$

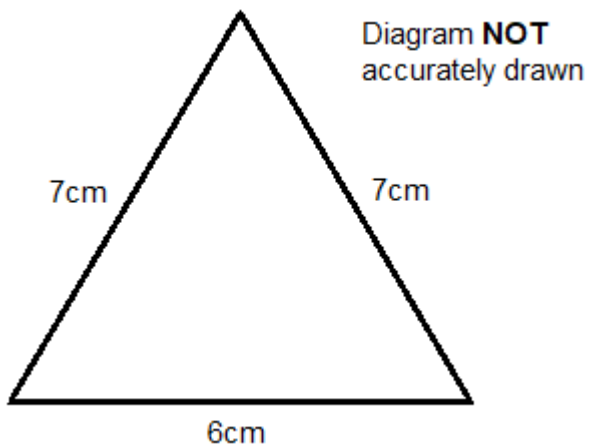

Q30

A rectangle is three times longer than it is tall. If the area of the rectangle is 48 square cm, what is the length of the rectangle?

Section 4: Statistics and Probability

All questions are worth one mark

Q31

Jan likes to play chess

The probability that Jan will win his next chess match is 0.5

The probability that Jan will draw his next chess match is 0.3

What is the probability that Jan will lose his next match?

Q32

There are 25 donuts in a box.

12 of the donuts are iced.

7 of the donuts are jam filled

The rest of the donuts are custard filled

Basia takes a donut from the box.

Work out the probability that Basia takes an iced or jam filled donut.

Questions 33 to 34 are based on the following information.

Kuba throws a 6-sided biased dice once.

The table shows the probability that the dice will land on 1, 2, 3, 4 or 5

Number	1	2	3	4	5	6
Probability	0.12	0.2	0.05	0.18	0.25	

Q33

Write down the probability that the dice will land on 6

Q34

Work out the probability that the dice will land on a prime number.

Q35

We know that 30% of cars on the roads are silver or grey.

If we go to a carpark with 40 cars, how many can we expect to be silver or grey?

Q36

Zara wants to take 5 suitcases on her trip.

After weighing the first 4 cases the average weight of her cases is 18kg.

After all 5 cases are weighed the average is 19kg.

What was the weight of the last case?

Section 5: Extended problems
All questions are worth two marks

Q37

The diagram shows a triangle and a rectangle.
All measurements are in centimeters.
The area of the triangle is twice the area of the rectangle.
What is the value of x ?

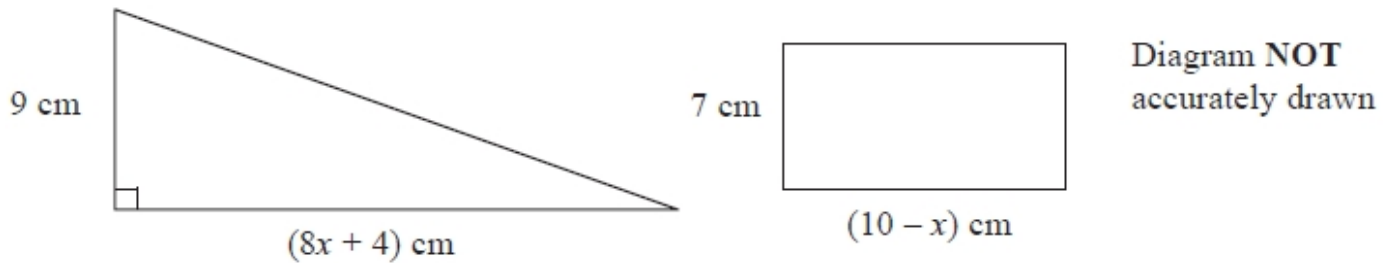

Q38

Six years ago Ewa was 8 years younger than Laura. If Laura is now twice Ewa's age, what age was Ewa six years ago?

Q39

If a square of side length x has its area doubled but remains a square, what is the ratio of the new square's side length to its original?

Q40

Expand and simplify $(x + y)(x + y)(x + y)$
what is the value of a in the term axy^2

End of test